

# L-M12-1M03020S30CV1

S-Mount Lens M12 x 0.5

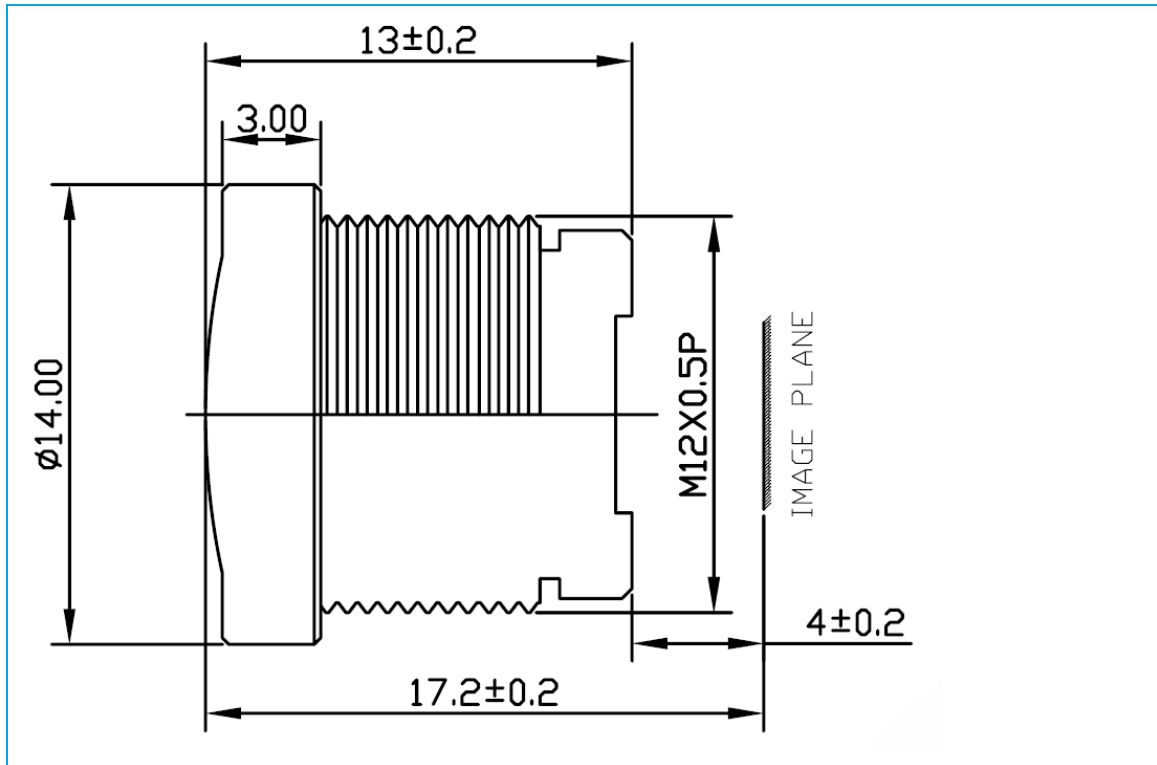

Technical Data	
Mount	S-Mount
Sensor	1/3 inch
Focal Length	3 mm
Aperture	2
MOD	0.2 m
Back Focal	5.35 mm
Angle of View	D:124° H:98° V:71°
Megapixel	1-2 MP
IR Cut Filter	Yes
Distortion	-88 %
Weight	4 g
Iris	fixed
Focus	fixed
Typ	Standard

Rev. 1.01-1802

Please note that all data and illustrations are subject to error, change and omissions without notice.